

Electrification is changing the construction sector:

“How new models, pre-competitive standards and sustainability benefits emerge”

04-06-2026, ERA conference Maastricht

# Agenda

1. Why electrification is coming your way (the benefits)
2. Details that make the difference
3. Responding as a rental company

# 1. Why the combustion engine is ending in construction.

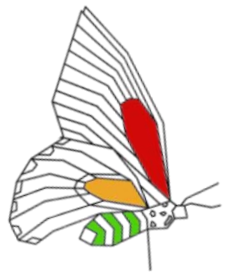

- **No technical barrier** to go electric for drive trains in all segments.
- Energy conservation = electric drivetrain **efficiency 4:10** compared to ICE
- Degrading nature = need to **reduce NOx**
- Degrading climate = need to **reduce CO<sub>2</sub>**
- Degrading Health = need to **reduce PM**
- Occupational H&S = **DME elimination, less noise and vibrations**
- Electricity = **energy autonomy**

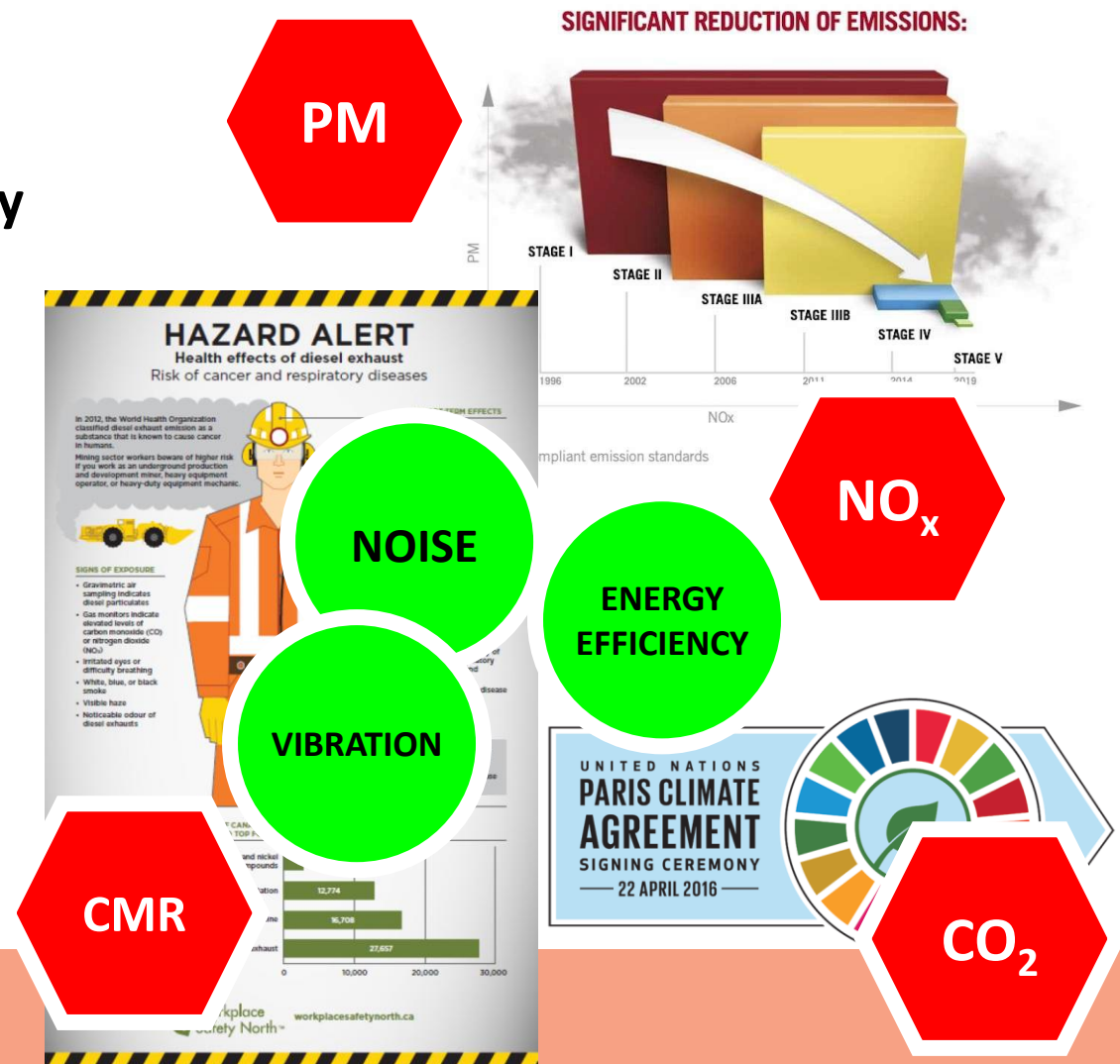

# 1. Selective development

- NL = Big machines, NOx driven
- Scandinavia = Smaller/Tunnel machines, PM and CO<sub>2</sub> driven
- Extractive industries global = Loaders and dumpers, economics driven
- Rest of Europe = slow and diverse



## Electric Heavy Truck Registrations Q1-Q3 2025

Share of new electric trucks within total heavy truck registrations

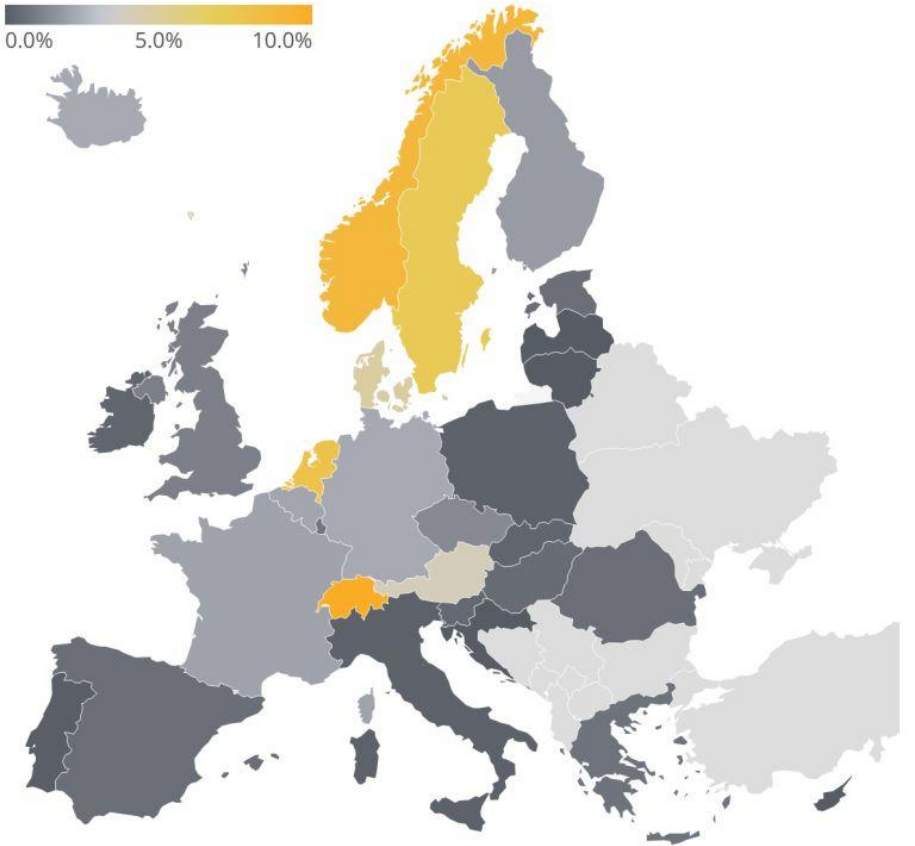
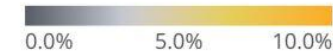

Map: Freight Perspectives • Source: ACEA

bron: [ACEA](#)

**ZEN**



**IN TRANSITION**

# Agenda

1. Why electrification is coming your way
2. Details that make the difference
3. Responding as a rental company











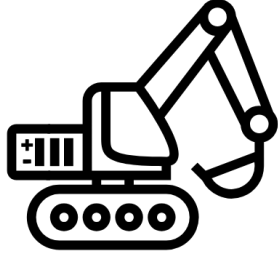





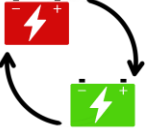
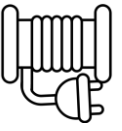
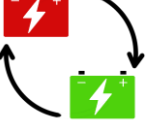

## 2. What details?

- a) Location / distance to grid
- b) Size, type and numbers
- c) Working hours
- d) Duration
- e) Standards

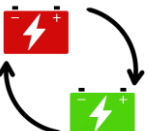

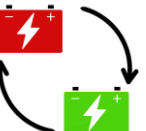
# 2. Preferred charging regimes on ZE construction sites

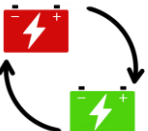

Distance to grid	# shifts	 Mobile machinery (e.g. wheeled)	 Immobile machinery (e.g. tracked)
Close to grid connection		 From GRID	 To GRID /  From GRID
		 From GRID / 	 To GRID /  /  From GRID
Grid connection at a distance		 Drive to GRID /  From BESS / GenSet	 To BESS / GenSet /  /  From BESS / GenSet
		 /  From BESS / GenSet	 To BESS / GenSet /  /  From BESS / GenSet

# Agenda

1. Why electrification is coming your way
2. Details that make the difference
3. Responding as a rental company

# 3. Standardisation is key

- Electric construction equipment is diverse, low-volume and emerging.
- Lots of differences in terms of design and operation of machines.
- **Lots of compatibility issues across brands, especially with (smart) charging.**
- Lots of best practices yet to emerge in a largely unregulated segment.

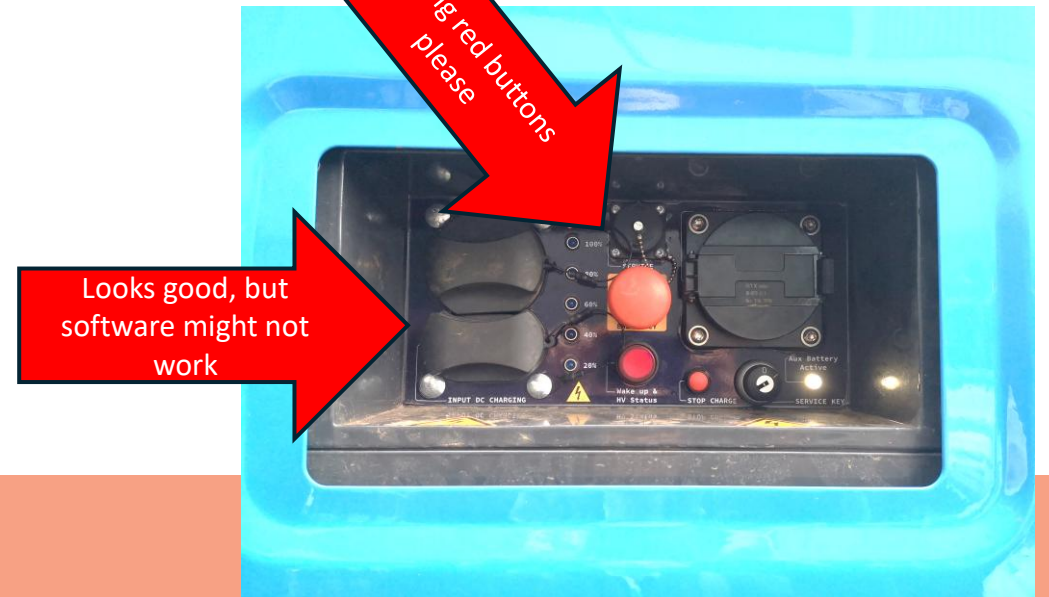

# 3. Cooperate like there is no tomorrow

## What to do:

- **Demand standardisation quickly** on charging, safety, data & batteries to ensure interoperability and easy user adaptation!
- **Collectively formulate procurement guidelines** for electric machines for rental companies
- **Seek cooperation with related initiatives** like the OEM Roundtable, not duplication



# The OEM Roundtable on voluntary market standards of electric plant

**KOMATSU**

**LIEBHERR**

**V O L V O**

**VDL**  
VDL ETS



**LIUGONG**



*MoU partners at Inception meeting, Bauma 2025, Munich*

A key characteristic of this Roundtable is the proactive input of expertise and experiences from all participants.

**Pre-competitive, voluntary, practical!**



*Parts of the group on the 11<sup>th</sup> workshop, May 2026, Arnhem*

**ZEN**



**IN TRANSITION**

# The OEM Roundtable Sounding Board

The Sounding Board consists of end users and rental companies that provide input and feedback to the recommendations.



renta



SKISTAR

+ PURE ENERGY



FMIB



ZEN



IN TRANSITION

# Topics on the agenda













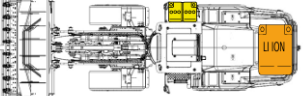

Category	Topic title	Status
Physical features charging	Light indicators and labels at charge plug	Published
Physical features charging	Provisions for first responders	Published
Physical features charging	Position of charge plug on the machine	Published
Physical features charging	Function of the emergency stop button	Published
Charging	Charging protocols	Published
Data and Information	Communication of equipment specifications an end-user actually needs/wants	In progress
Data and Information	Definition of datapoints an end-user actually needs/wants	In progress
Charging	Uniformity and interoperability of high-speed DC charging (MCS/CCS/EMS)	In progress
Interface with electric attachments	Standards to be used for electrical connections between attachments and machine.	On backlog
Tethered connection	Connection standards for a tethered machine	On backlog
Swappable Battery	Standardisation of swappable batteries	On backlog
Swappable Battery	(GPS) information on swappable batteries	On backlog
Charging	Uniformity of low voltage DC charging	On backlog

# Recommendation #1

## Provisions for professional first responders in line with ISO17840

- Mark vehicles with energy pictogram
- Make emergency response guide available through QR code on the machine
- Put your machine into emergency response databases if available



	<b>VOLVO Electric Wheel loader</b> L120 Electric		
			
<p>≥19 ton vehicle              8 High voltage battery packages in rear              1 door left side              1 window to open right side              1 door rear side for charging              1 Seat</p>  			
			
High voltage battery	High voltage component	Battery, low-voltage	Disconnect high voltage device
			
Tank content oil	Device to shut down power in a vehicle		
			
Steering wheel, air control	Seat height adjustment by air system		
Identification number		Version number	Page number
S4172043		02/2024	1

# Recommendation #2

## Light indicators of the charging process on the machine

- Use lights, preferably as explained
- Clarify lights with labelling next to the plug.



State	Light Indication
Ready to charge / connecting:	Solid yellow or white
Charging in progress:	Pulsating blue or green
De-charging of vehicle in progress:	Different colouring and pulse frequency than with charging
Charging completed:	Solid Green
Error:	Red

# Recommendation #3

## Location of all charging sockets on the machine should be predictable

- All sockets should be located at the same place on the machine;
- located on the same side as the cabin entry (often left);
- visible from the point of entry into the machine cabin;
- reachable from the ground.

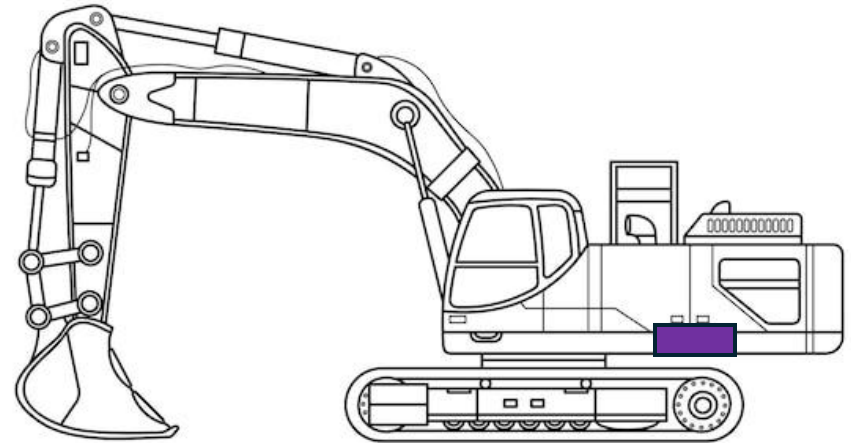

# Recommendation #4

## Big red buttons / Emergency stop buttons for charging

- Emergency stop button specifically for charging should be located on the charger, not on the machine.



# Recommendation #5

## Priority charging protocol for DC charging via CCS2

- ISO 15118-2 = default priority charging protocol
  - > Smart charging
  - > Authentication and Authorisation
  - > Cybersecurity
  - > plug & charge
  
- ISO 15118-20 = 'nice to have' (for the moment)
  - > vehicle to X



<b>Application</b> OSI layer 7		<b>ISO 15118-2</b>	Application layer messages (V2G Message), SDP (SECC Discovery Protocol)		
<b>Presentation</b> OSI layer 6	<b>ISO 15118-1</b>	Network and application protocol requirements	EXI (Efficient XML Interchange)		<b>ISO 15118-4</b>
<b>Session</b> OSI layer 5	General information and use case definition	<b>ISO 15118-20</b>	V2GTP (Vehicle-to-Grid Transfer Protocol)		
<b>Transport</b> OSI layer 4	(merged with contents of ISO 15118-6 for second edition)	2 <sup>nd</sup> generation network and application protocol requirements	UDP (User Datagram Protocol), TCP (Transmission Control Protocol), TLS (Transport Layer Security)		
<b>Network</b> OSI layer 3			IP (Internet Protocol), SLAAC, DHCP		
<b>Data link</b> OSI layer 2		<b>ISO 15118-3</b>	<b>ISO 15118-5</b>	<b>ISO 15118-8</b>	<b>ISO 15118-9</b>
<b>Physical</b> OSI layer 1		Physical and data link layer requirements	Physical and data link layer conform. tests	Physical and data link layer requirements for wireless communication	Physical and data link layer conformance test for wireless comm.

# View, consider, endorse & adopt recommendations for your fleets:

The screenshot shows the website's navigation menu with options like 'Achtergrond', 'Organisatie', 'Techniek', 'Partners', 'Actualiteiten', 'Evenementen', 'FAQ', 'English', and 'Contact'. A yellow 'Intranet' button is also visible. The main content area is titled 'PUBLISHED RECOMMENDATIONS'. The first recommendation is titled 'Recommendation #1' with the topic 'Provisions for professional first responders'. Below the topic is an executive summary and a paragraph of text. A blue button labeled 'Download the full text #1 here' is positioned below the text. To the right of the recommendation is a registration form titled 'Registration of interest in the ENI/ElaadNL OEM roundtable'. The form includes fields for 'Name of organisation', 'Type of organisation', 'Your name', 'Your job title', 'Your email', and 'Your phone number'. There is also a checkbox for 'I'm not a robot' and a 'Register' button at the bottom.



[ENI / ElaadNL OEM Roundtable for open market standards | Emissieloos Network Infra](#)

## Recommendation #2

Topic: Light indicators of the charging process on the

## The topics that are on the table

We have a dynamic longlist of topics that are feeding the agenda of individual

Let's talk..

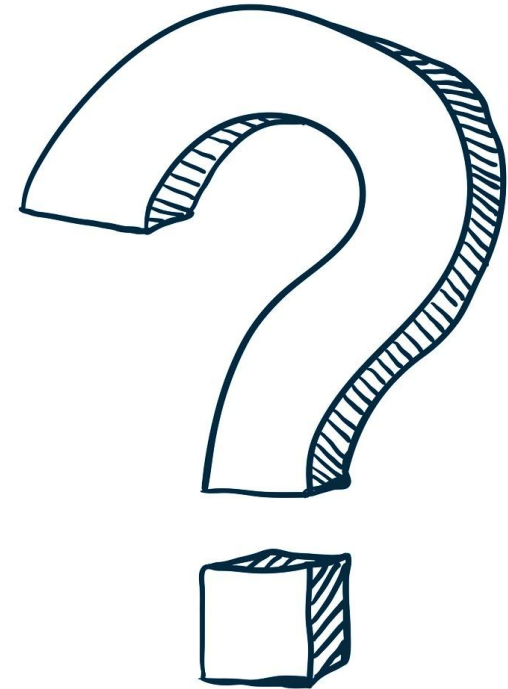

**ZEN**



**IN TRANSITION**

# Thank you for your attention!



## Tobias Stöcker

Facilitator and advisor for Zero Emission Construction (Networks)



[tobias@zen-in-transition.eu](mailto:tobias@zen-in-transition.eu)

[zen-in-transition.eu](http://zen-in-transition.eu)